

# Jordan TOF Products, Inc.

*Formerly R. M. Jordan Co., Inc.*

990 Golden Gate Terrace — Grass Valley, CA 95945

VOICE: 530-272-4580 FAX: 530-272-2955

WEB: [www.rmjordan.com](http://www.rmjordan.com)

EMAIL: [info@rmjordan.com](mailto:info@rmjordan.com)

## **THE Z-GAP DETECTOR**

Most detectors used for TOF are of Dual Microchannel Plate (MCP) configuration. Two plates are stacked so that their channels form an angle (like the letter V). This is also known as the chevron configuration, or chevron stack. Gain of a dual MCP is over  $1 \times 10^6$ . This is usually adequate for most laboratory applications.

For more gain, some have added a third plate so that the channels in the plates form an angle (like the letter Z). This is usually referred to as a Z-Stack. Gain of a triple MCP detector is as much as 100 times higher than the dual MCP. There is a problem, however. Signal/noise ratio is poor. Signal/noise ratio is usually considered to be more important than simply higher gain.

We have designed a detector that has the high gain of the triple, or Z-Stack, but with excellent signal/noise ratio. This feature is built into the mechanical assembly and we call it the Z-Gap. It has higher gain than the triple, and lower signal/noise ratio than the dual MCP detector.

With the Z-Gap detector, the incoming ions impact the first (ion/electron conversion) surface, which is at a potential of between 3 and 5KV. This is almost twice as high as the dual MCP. Since detector sensitivity is proportional to impact velocity, the Z-Gap detector is more sensitive to higher mass ions.

These detectors will work dependably if the operating pressure is kept low and they are not bombarded with large ion peaks, or sustained ion current. The reason is that the gain is so high and the geometry so small that the electron/ion density can be sufficient to create a conductive path. This causes internal arc-over, which destroys at least one plate, usually the last one.

Typically the threshold operating voltage for a new assembly is about 2.6KV, safe operating voltage about 3.0KV and the maximum safe voltage about 3.5KV. As the detector ages it becomes less sensitive and the operating level can be increased.

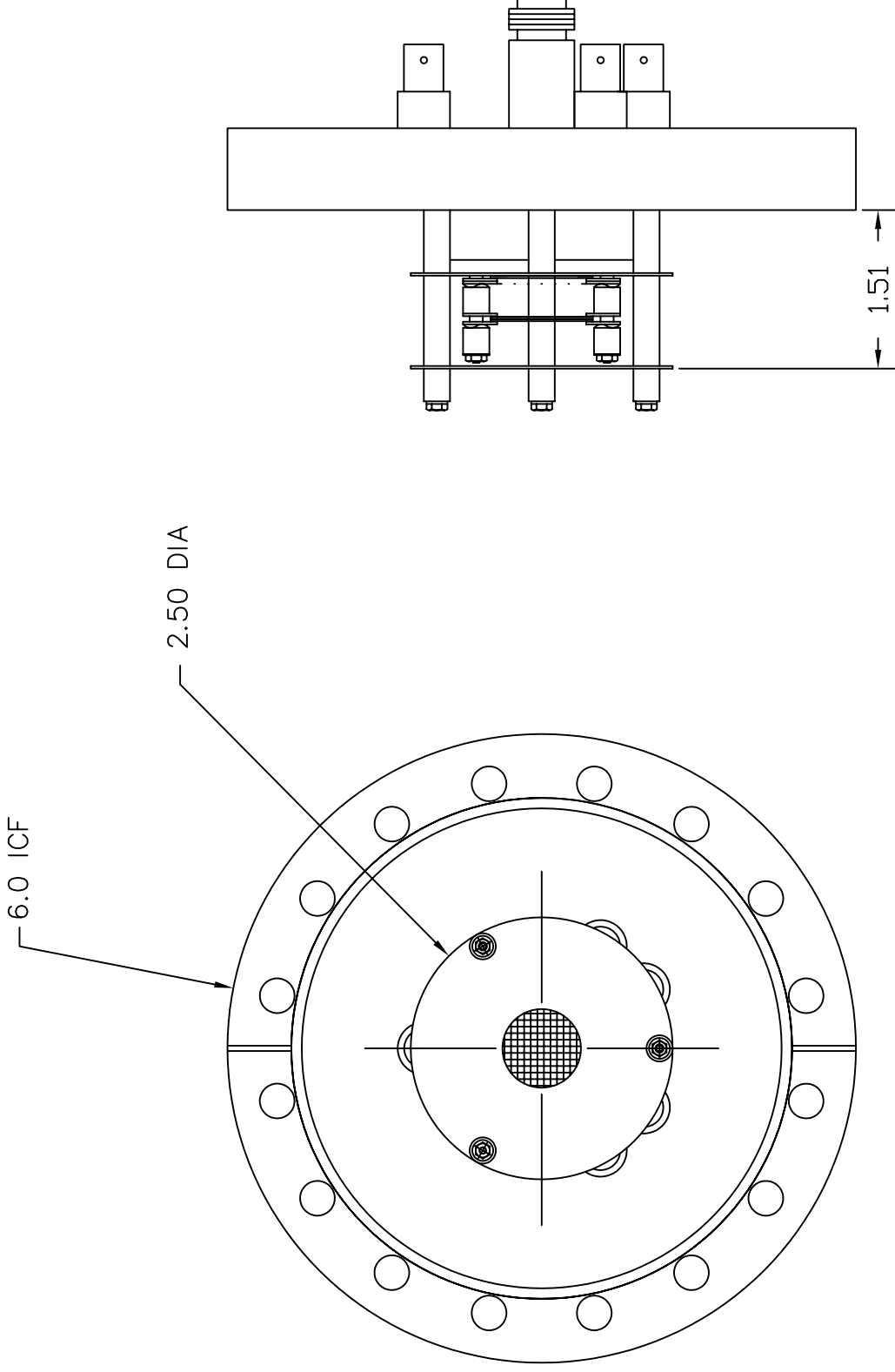

18MM Z-GAP CHANNEL PLATE DETECTOR  
 JORDAN TOF PRODUCTS, INC.  
 Grass Valley, CA  
 C0701Z REV 11-14-14

